

User Manual

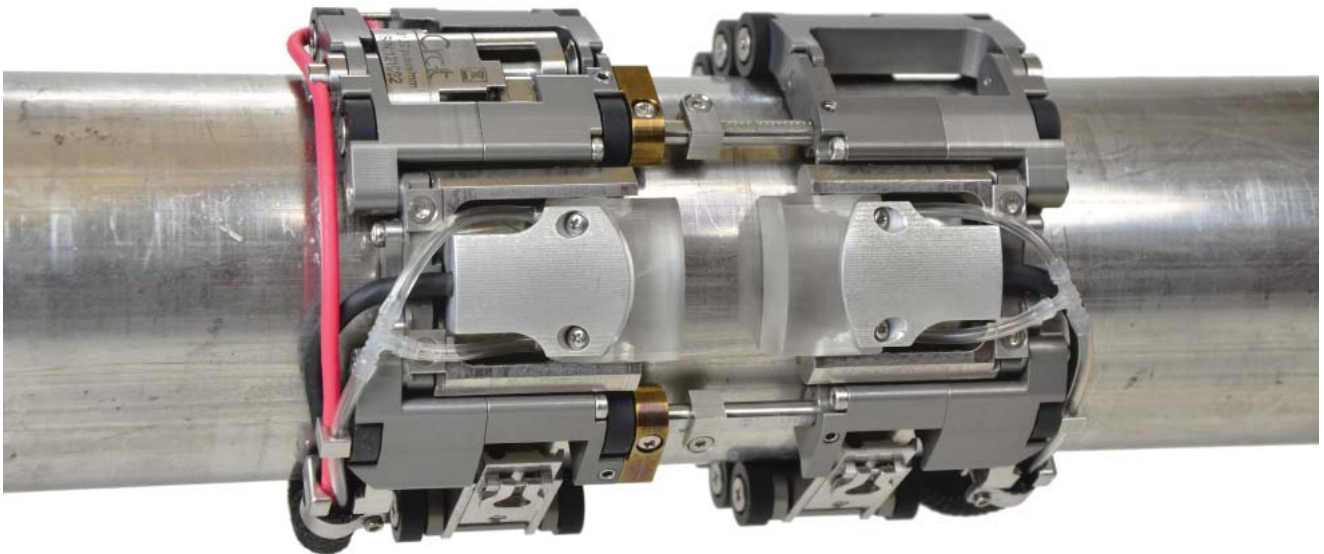

Low Profile Small Diameter Scanner



KEEP THIS MANUAL – DO NOT LOSE

THIS MANUAL IS PART OF THE CIRC-IT SYSTEM AND MUST BE KEPT FOR THE LIFE OF THE PRODUCT. PASS ON TO SUBSEQUENT OWNERS.

Ensure any amendments are incorporated with this document.



CAUTION! The Circ-it is designed for a specific use. Using the Circ-it outside of its intended use could cause damage to the product. Read and understand this manual before using.

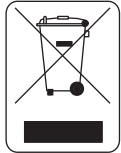

The WEEE symbol indicates that the product must not be disposed of as unsorted municipal waste, but should be collected separately.

- 1. Specifications.....3**
 - 1.1. Intended Use.....3
 - 1.2. Performance Specifications3
 - 1.3. Operating Environment3
- 2. Preparation for Use.....3**
 - 2.1. Items Required for Scanner Setup.....3
 - 2.2. Scanner Component Identification4
 - 2.3. Dual Probe Scanner Setup5
 - 2.4. Single Probe Scanner Setup.....7
 - 2.5. Installing Probes and Wedges7
 - 2.6. Setting Wedge Spacing.....10
 - 2.7. Using Wedge Separation Indicators.....10
 - 2.8. Irrigation Lines & Probe/Encoder Connections12
- 3. Operation12**
 - 3.1. General Scanner Operation12
 - 3.2. Single-sided Access Operation13
- 4. Maintenance14**
- 5. Troubleshooting.....15**
- 6. Spare Parts16**
- 7. Circ-it Setup Chart17**

DISTRIBUTOR:



MANUFACTURER:

Jireh Industries Ltd.

53158 Range Road 224
Ardrossan, Alberta, Canada
T8E 2K4
Phone: (780) 922-4534
Fax: (780) 922-5766
www.jireh-industries.com

1. Specifications

1.1. Intended Use

The Circ-it is a manual small diameter scanner. It is designed to provide encoded position of probes circumferentially around piping and tubing. The pipes/tubes must be:

- free of debris, scale, soot, etc.;
- no smaller than 21.3mm (0.840") outer diameter;
- no larger than 114.3mm (4.500") outer diameter.

The Circ-it is intended for both dual and single probe scanning applications.

The Circ-it is intended to operate in an environment as described in Section 1.3 "Operating Environment".

1.2. Performance Specifications

Table 1 – General Specifications

Scanner Diameter Range	0.840" (21.4mm) – 4.50" (114.30mm)
Scanner Width*	1.98" (50mm)
Encoder Resolution	32.08 pulses/mm
Environmental Sealing	IP67
Required Radial Clearance*	0.433" (11.0mm)

* Scanner only. Transducers and wedges not included.

1.3. Operating Environment

The Circ-it is designed for use in an industrial environment that is between -40°C and 80°C.

2. Preparation for Use

2.1. Items Required for Scanner Setup

The following supplied tools are required for assembly, re-configuration, and adjustment of the scanner:

- T6 Torx Screwdriver
- Philips Head Screwdriver
- Loom Installation Tool
- Circ-it Sizing Chart

2.2. Scanner Component Identification

The Circ-it system consists of the components shown in Figure 1 - Figure 8.

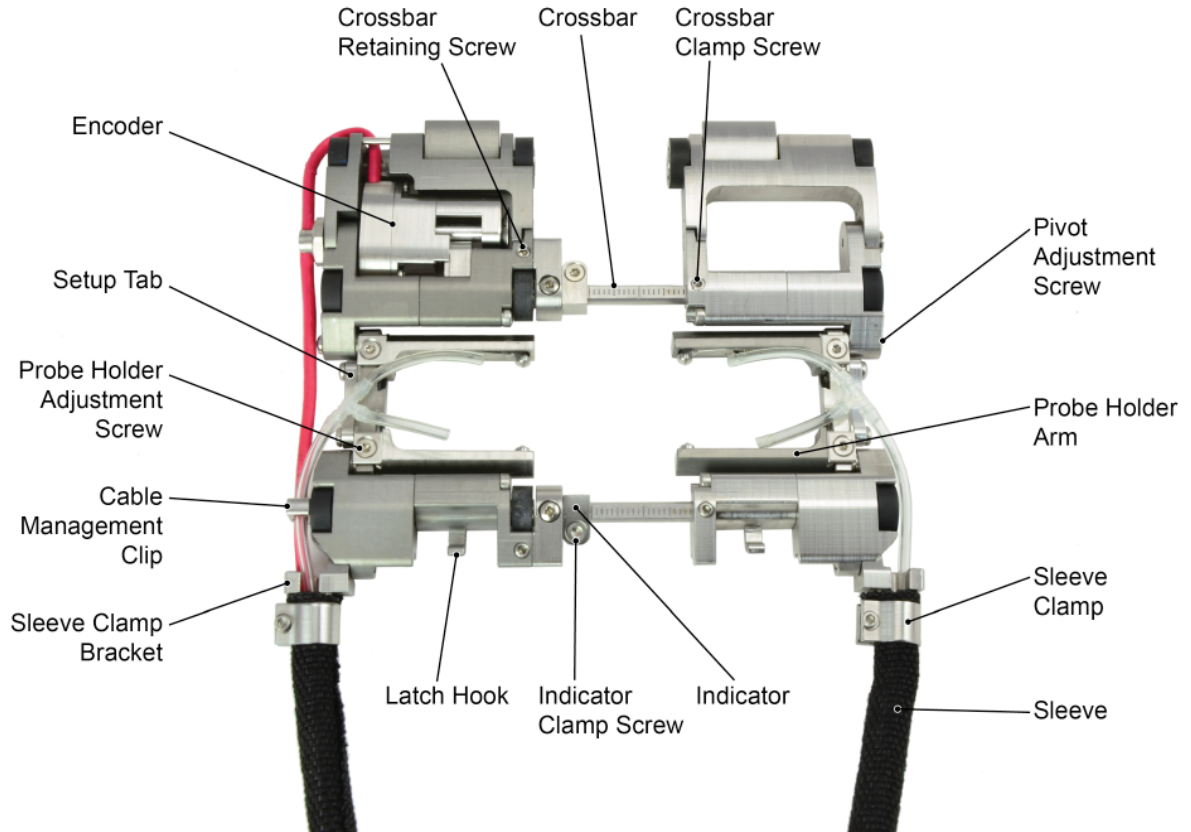

Figure 1 - Scanner Assembly (laid out flat)



Figure 2 - Long Link



Figure 3 - Medium Link



Figure 4 - Short Link



Figure 5 - Wheel Block



Figure 6 - Short Latch



Figure 7 - Long Latch



Figure 8 - Irrigation Hose & Splitter

2.3. Dual Probe Scanner Setup

NOTE: Scanner setup should be carried out in a clean, well-lit area on a flat and level work surface.

To setup the Circ-it, follow these steps:

- Install probes and wedges (see section 2.4. *Installing Probes and Wedges*).
- If desired, set probe spacing (see section 2.5. *Setting Wedge Spacing*).
- Confirm tube or pipe O.D. to be scanned.
- Use Circ-it Setup Chart (page 17) to determine link and pivot combination required.
- Install links and pivots as shown (see Figure 9 - Figure 13). Alternate wheel blocks and links so that the links are always separated by a joint (i.e. a link is never attached directly to another link).



Figure 9



Figure 10



Figure 11



Figure 12



Figure 13

- f. Lower setup tab by loosening the two screws on either side of the tab (see Figure 14). After the setup tab has been lowered, retighten the screws on either side of the tab.



Figure 14 - Lowering Setup Tab

- g. Loosen pivot adjustment screws 1/8th turn to allow for adjustment (see Figure 15).

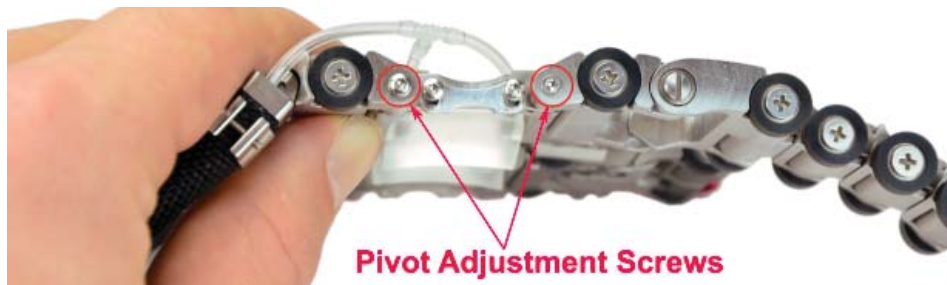

Figure 15 - Loosening Pivot Adjustment Screws

NOTE: It is not necessary to loosen pivot adjustment screws beyond 1/8th turn as doing so will create unwanted movement in the scanner making proper setup more difficult.

- h. Install scanner on an open ended tube/pipe (see Figure 16). Wrap the scanner around the tube/pipe and connect the latch to the main scanner assembly. Before tightening pivot adjustment screws, ensure that all wheels and both indicator points of the setup tab are contacting the tube/pipe surface and the latch is fully engaged.
- i. Tighten pivot adjustment screws with the scanner wrapped around the tube/pipe (Figure 17).



Figure 16



Figure 17

- j. Remove scanner from tubing or pipe and place on a hard, flat surface.
- k. Raise setup tab to original position (Figure 18).



Figure 18 - Raising Setup Tab

- l. Repeat process for the opposite side.

2.4. Single Probe Scanner Setup

To use the Circ-it in a single probe scanning configuration, follow these steps:

- a. Loosen crossbar bracket retaining screws and slide the non-encoded side of the scanner assembly away from the encoded side (Figure 19 - Figure 20).

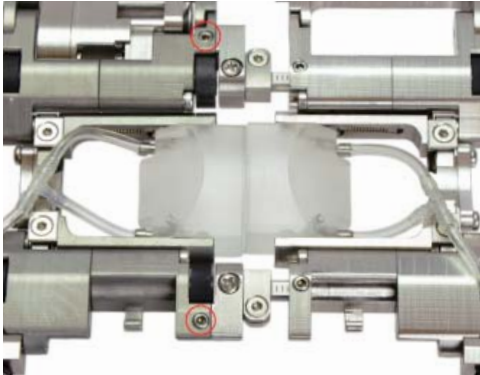

Figure 19



Figure 20

- b. Repeat steps a-k from section 2.3. *Dual Probe Scanner Setup* using the single probe scanner assembly.

2.5. Installing Probes and Wedges

To install probes and wedges on the Circ-it, follow these steps:

- a. If present, remove both chain assemblies from scanner
- b. Loosen pivot adjustment screws (Figure 21) and fold scanner in hand as shown in Figure 22.

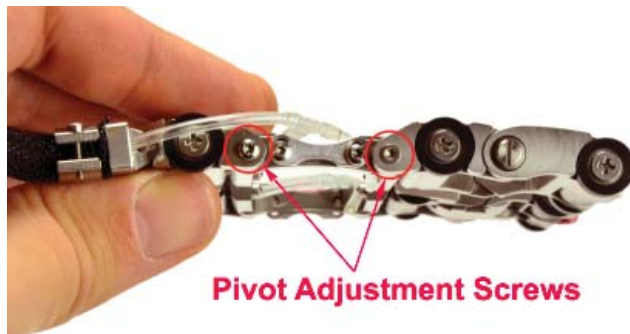

Figure 21 - Loosening Pivot Adjustment Screws



Figure 22 - Fold Scanner in Hand

- c. Loosen probe holder adjustment screws (Figure 23) 1/8th turn to relieve clamp pressure. When the probe holder arms are free to move, slide arms apart (see Figure 24).



Figure 23

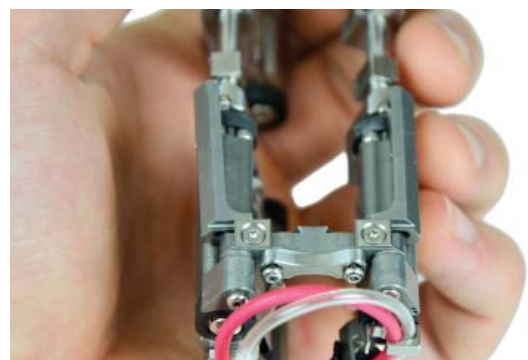

Figure 24

NOTE: It is not necessary to remove probe holder arms. Be sure to only loosen and slide apart.

- d. Install wedge by matching the pivot holes with the probe holder arm pivot buttons (see Figure 25 - Figure 26).



Figure 25 - Pivot Button



Figure 26 - Probe Installation

- e. Center the wedge and probe holder arms as shown in Figure 27.
- f. Tighten probe holder adjustment screws. Ensure that the wedge is free to rotate about the pivot buttons before tightening.
- g. Remove the sleeve clamp screw (Figure 28) and slide the protective sleeving and sleeve clamp from the scanner assembly (Figure 29). Remove the sleeve clamp and protective sleeving from the irrigation tube and encoder cable (encoded side only) if applicable.

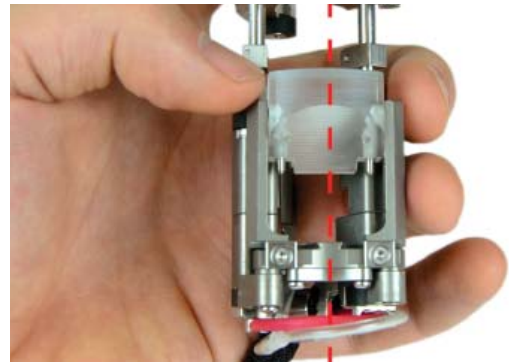

Figure 27



Figure 28



Figure 29

- h. Insert the irrigation tube, encoder cable (encoded side only), and probe cable in the cable management clip (Figure 30) and run cable/tube bundle through the sleeve clamp bracket (Figure 31).



Figure 30



Figure 31

- i. Use the loom installation tool to install the protective sleeving over the cable/tube bundle. To do this, start at the scanner end and follow these steps:
 - i. Close the tool over the bundle with the pointed shoe portion pointing away from the scanner.
 - ii. Slide the protective sleeving over the pointed shoe portion of the tool so that it spreads open, follows the tool, and starts to wrap itself around the bundle.
 - iii. While holding the portion of the protective sleeving that is already around the bundle, slide the tool away from the scanner so that the remainder of the protective sleeving wraps around the bundle.



Figure 32

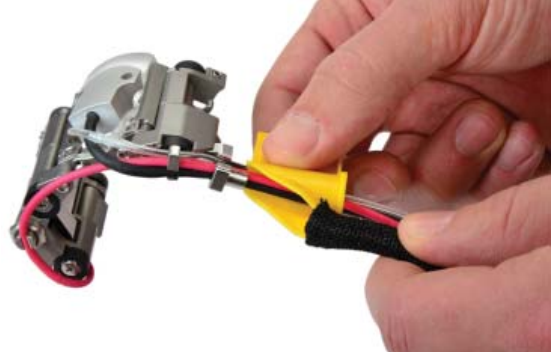

Figure 33



Figure 34



Figure 35

- j. Re-install the sleeve clamp over the cable/tube bundle (Figure 36) and slide it over the protective sleeving as shown in Figure 37 (be aware of the clamp orientation). Install the sleeve clamp screw so the threads just start to engage in the sleeve clamp.
- k. Slide the protective sleeving over the sleeve clamp bracket on the scanner assembly. Work the sleeve clamp into position and tighten the sleeve clamp screw until sufficiently snug. Ensure the sleeve clamp is oriented so that the sleeve clamp screw will not protrude lower than the scanner wheels and rub on the inspection surface (see Figure 38).

NOTE: Do not over tighten sleeve clamp screw. Over tightening will cause screw to break.



Figure 36



Figure 37



Figure 38

- l. Repeat process for the opposite side

2.6. Setting Wedge Spacing

To set the wedge spacing, follow these steps:

- a. If present, remove both chain assemblies from scanner
- b. If wedges are not installed, proceed to section 2.5. *Installing Probes and Wedges*
- c. Loosen pivot adjustment screws (Figure 39) and push scanner against a flat surface (Figure 40)

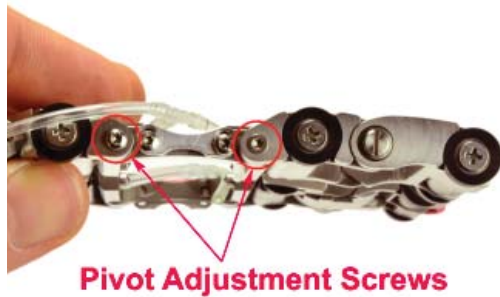

Figure 39 - Loosening Pivot Adjustment Screws

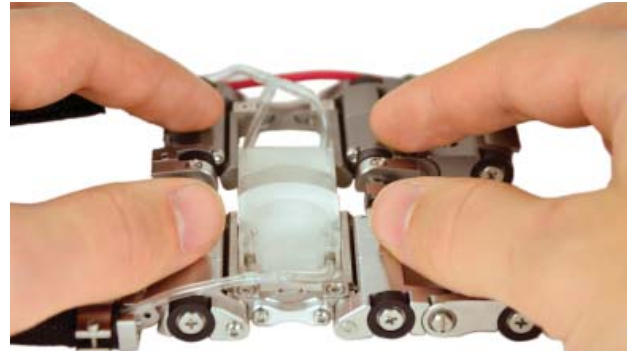

Figure 40

- d. Loosen both crossbar clamp screws (Figure 41) located on the non-encoded side of the scanner

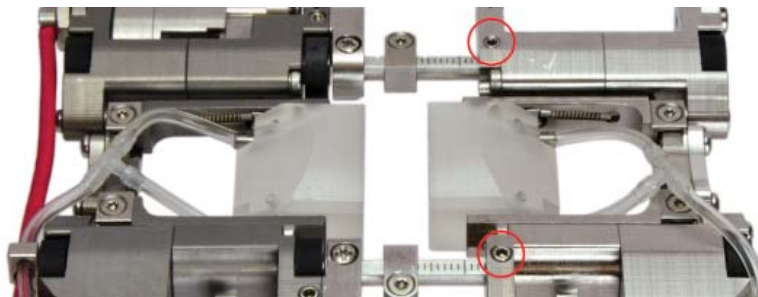

Figure 41 - Loosening Crossbar Clamp Screws

- e. Slide encoded and non-encoded chain to desired separation and tighten the crossbar clamp screws

2.7. Using Wedge Separation Indicators

To use the wedge separation indicators to set wedge spacing, follow these steps:

- a. If present, remove both chain assemblies from scanner
- b. If wedges are not installed, proceed to section 2.5. *Installing Probes and Wedges*
- c. Loosen pivot adjustment screws (Figure 39) and push scanner against a flat surface (Figure 40)
- d. Loosen both crossbar clamp screws (Figure 41) located on the non-encoded side of the scanner
- e. Slide the wedges together till they make contact with each other (Figure 42)



Figure 42

- f. Loosen the indicator clamp screws (Figure 43).

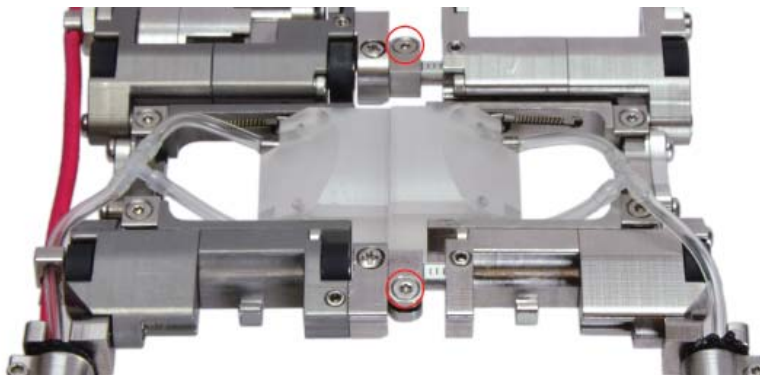

Figure 43

- g. Slide the indicator to the non-encoded side of the scanner (Figure 44).

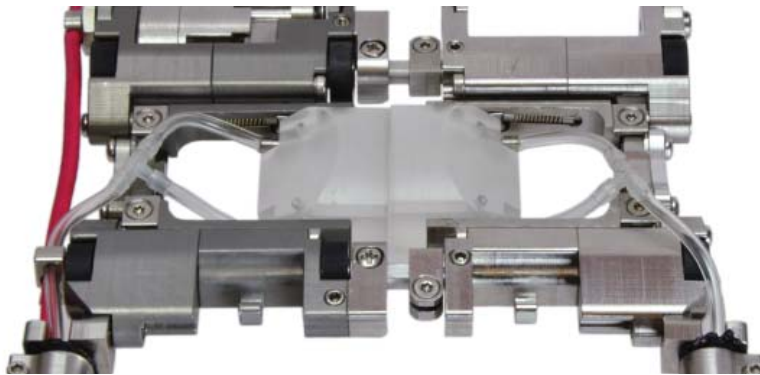

Figure 44

- h. Tighten the indicator clamp screws.
- i. Slide the chains apart till desired wedge separation is achieved. The number of graduations between the indicator and non-encoded side of the scanner is the probe separation in mm as shown in Figure 45.

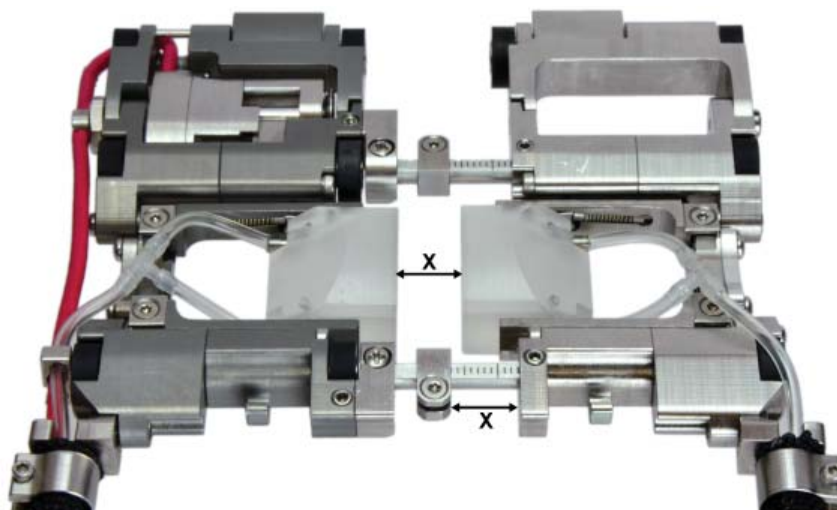

Figure 45 - Wedge Separation Indication

- j. Tighten both crossbar clamp screws.

2.8. Irrigation Lines & Probe/Encoder Connections

Use the following diagram to assist in connecting the irrigation lines and probe/encoder cables:

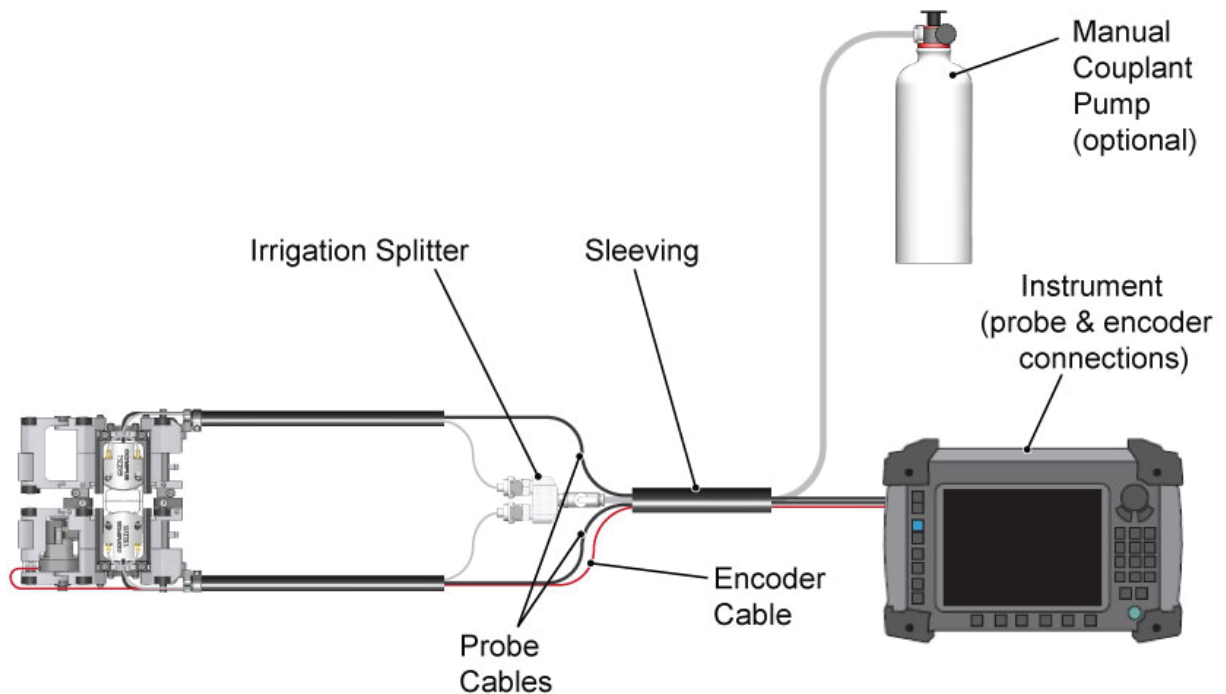

Figure 46 - Connecting irrigation lines and probe/encoder cables

3. Operation

3.1. General Scanner Operation

For scanner operation with access to all sides of pipe/tube to be scanned, follow these steps:

- Place scanner assembly with attached chain around pipe/tube.
- Lift latch on the end of the chain (Figure 47) and pull toward scanner assembly (Figure 48).
- Allow latch to 'click' into place in the tightest notch possible (Figure 49). Ensure that proper probe contact is made with scanning surface. If probe contact is not adequate, see *Section 2.3. Dual Probe Scanner Setup* to re-adjust scanner assembly.



Figure 47



Figure 48



Figure 49

- d. Pivot latch into flat position before initiating scan (Figure 50 - Figure 51).



Figure 50



Figure 51

3.2. Single-sided Access Operation

To configure the Circ-it for applications where access to pipe/tube is single-sided, use the supplied installation hook tool and the following sequence of photos to assemble the scanner:



Figure 52



Figure 53



Figure 54



Figure 55



Figure 56



Figure 57



Figure 58



Figure 59



Figure 60



Figure 61

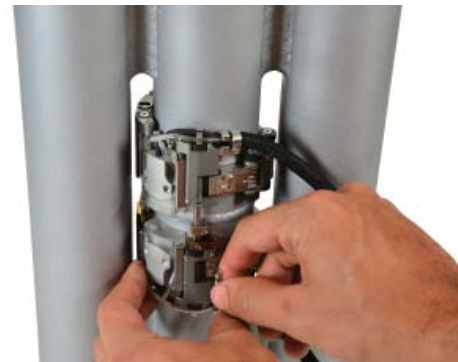

Figure 62



Figure 63 - Ready for scan

4. Maintenance

Wipe the scanner clean as required. Do not soak or submerge the scanner in cleaner or solvent of any kind.

5. Troubleshooting

Problem	Possible Cause	Solution
1. Chain is too loose/ tight	Incorrect number or combination of links for proper scanner configuration.	Refer to the Circ-it Setup Chart (page 17) for required number of links for the diameter of pipe/tube you are scanning. Remember to use the Outer Diameter measurement of your pipe/tube. Re-setup the scanner with the correct number of links. See section 2.3.
	Incorrect latch setting.	There are two notches on the short and long latches. Ensure that the latch is on the tightest notch possible after the correct number of links are used.
	Incorrect latch used.	Refer to the Circ-it Setup Chart (page 17) for proper latch (Short or Long) to use for the diameter of pipe/tube you are scanning. For pipe/tube less than 2" OD, use the short latch. For pipe/tube greater than 2" OD, use the long latch.
2. Insufficient probe contact.	Scanner not set properly.	Reconfigure the scanner as per instructions in sections 2.3 or 2.4.
	Pivot Adjustment Screws were not tight enough and scanner spread apart upon installation on pipe/tube.	Reconfigure the scanner as per instructions in sections 2.3 or 2.4.
	Setup tab not raised.	With the scanner removed from the pipe/tube, raise the setup tab by loosening the two screws on either side of the tab. There is a setup tab on each side of the scanner. Refer to section 2.3 or 2.4 for proper use of the setup tab.
	Tube/cables routed incorrectly.	Refer to section 2.5 for proper probe installation and cable management.
3. Encoder cable clip rubbing on tube/pipe	Incorrect pivot adjustment and/or incorrect setup tab adjustment.	Refer to section 2.3, specifically points f-k, to correct the pivot adjustment and use the setup tab for proper scanner operation. Ensure the contact points on the setup tab are against the pipe/tube surface before tightening pivot adjustment screws.

6. Spare Parts

Refer to Figure 64 for spare parts.

ITEM	QTY	PART NUMBER	DESCRIPTION	ITEM	QTY	PART NUMBER	DESCRIPTION	ITEM	QTY	PART NUMBER	DESCRIPTION
1	42	DGS006	Wheel	10	2	DJS017	Irrigation Tubes	18*	2.5m	LA074	4mm Tube
2	4	DJ0004	Probe Holder Arm Clamp	11	12	DJS006	Wheel Block	19*	1	CTL-SP036-1.500	Sleeve
3	2	DJS001-L	Probe Holder Arm, Left	12	2	DJS013-0.735	Short Link	20*	1	EA302	Loom Installation Tool
4	2	DJS001-R	Probe Holder Arm, Right	13	8	DJS013-1.125	Medium Link	21*	1	EA303	T6 Torx Screwdriver
5	1	DJS011-R	Crossbar Assembly, Right	14	10	DJS013-1.815	Long Link	22*	1	EA307	Size 0 Phillips Screwdriver
6	1	DJS011-L	Crossbar Assembly, Left	15	2	DJS012	Long Latch	23*	1	DJG002	Spare Fasteners Kit
7	1	DJS004-x	Encoder (specify connector type)	16	2	DJS008	Short Latch	24*	-	DJG003	Spare Parts Kit
8	2	DJ0013	Sleeve Clamp	17	1	DGS021	Irrigation Splitter	25*	-	DJG004	Encoder Replacement Kit
9	2	CTL-SP035-0.600	Sleeve	*NOT SHOWN							

Figure 64 - Spare Parts

7. Circ-it Setup Chart

Use the following chart to determine the number of links required for proper scanner setup.

Pipe/Tube OD		Link Type				Pipe	Tube
Min	Max	Short	Medium	Long	Wheel		
0.84	0.935	0	0	0	0	0.840	0.875
0.937	1.027	1	0	0	0		1.000
1.022	1.111	0	0	0	1	1.050	
1.111	1.199	1	0	0	1		1.125
1.196	1.283	0	0	0	2		
1.282	1.367	1	0	0	2	1.315	1.315
1.365	1.451	0	0	0	3		1.375
1.449	1.533	1	0	0	3		1.500
1.532	1.617	0	0	0	4		
1.614	1.698	1	0	0	4	1.660	
1.698	1.781	0	0	0	5		1.750
1.779	1.862	1	0	0	5		
1.862	1.945	0	0	0	6	1.900	
1.942	2.025	1	0	0	6		2.000
2.013	2.153	0	1	0	5		
2.142	2.28	1	2	0	4		2.250
2.272	2.409	0	3	0	4	2.375	
2.383	2.521	0	2	0	6		2.500
2.508	2.644	1	3	0	5		2.500
2.636	2.772	0	4	0	5		
2.762	2.893	0	1	2	4	2.875	
2.878	3.011	0	3	1	5	2.875	
2.994	3.124	0	0	3	4		3.000
3.113	3.244	0	2	2	5		
3.234	3.368	0	4	1	6		3.250
3.342	3.473	0	1	3	5		
3.466	3.598	0	3	2	6	3.500	3.500
3.569	3.7	0	0	4	5		
3.694	3.826	0	2	3	6		3.750
3.798	3.929	1	0	4	6		
3.92	4.051	0	1	4	6		
3.995	4.126	1	1	4	6	4.000	4.000
4.117	4.249	0	2	4	6		
4.192	4.324	1	2	4	6		
4.314	4.446	0	3	4	6		
4.415	4.547	1	1	5	6	4.500	4.500
4.538	4.67	0	2	5	6		

↑ Short Latch

↓ Long Latch