

Components and Accessories Catalog

JIREH

Custom Hardware & Automated Motion Solutions for the NDT Industry

Doc #CL-002

Jireh Industries Ltd.
53158 Range Road 224
Ardrossan, Alberta, Canada
T8E 2K4

phone: (780) 922-4534
fax: (780) 922-5766

email: info@jireh-industries.com
web: www.jireh-industries.com

Table of Contents

Microbe Components (BT)	01
Rotix Components (CE)	03
STIX System Components (BG)	05
Tri-Pod Components (AA)	08
Billy Goat Components (BA)	10
Y Axis Adjustment Components (CJ)	13
Accessories (CM)	14
Probe Holders (PH)	17
Umbilicals(UM)	19



Manual Magnetic Scanner

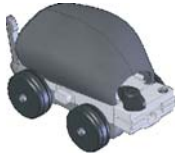

Microbe Body

BTA001

The Microbe Body comes complete with the integrated encoder base, brake, removable handle, Microbe nose four magnetic wheels and one removable knob.



Microbe Case

BTA002

A heavy duty polypropylene protective case, complete with custom milled high density foam inserts and pullout.



Microbe Body with Swivel

BTA003

The Microbe Body comes complete with the integrated encoder base, brake, removable handle, Microbe Swivel nose, and four magnetic wheels. The front swivel is used to hold a slide bar at different angles.



Microbe Body with Extension Arm Mount

BTA004

The Microbe Body comes complete with the integrated encoder base, brake, removable handle, eight magnetic wheels, and pole mounting kit.



Microbe Case - Large

BTA005

A heavy duty polypropylene protective case, complete with custom milled high density foam inserts and pullout. This case has a large pocket to accommodate a long or large umbilical

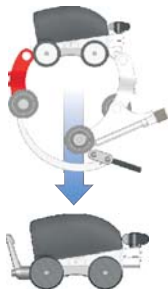

Rotix to Microbe Conversion Kit

BTG001

This conversion kit includes all components required to convert a Rotix system to a Microbe scanning system.

System includes:
1 BTS018 Brake
4 BTS031 Magnetic wheel
1 BTS032 Microbe nose



Rear Swivel Adapter

BTG003

This kit to be used to add a Microbe swivel to the rear of a Microbe body to allow probe holders to be used in the front and rear of the Microbe. To be used with BTS034 Swivel Nose.



Pole Mounting Kit

BTG004

This kit can be fitted to the Microbe body so it can be manipulated with a pole for scanning applications when the operator cannot reach the scanner. To be used with standard 5/8" threaded surveying poles.



Swivel Adapter Kit

BTG010

This conversion kit can be used to convert a Rotix chain scanner to a Magnetic Microbe scanner with a Swivel nose. Four magnetic wheels are included.



Brake

BTS018

The Brake features a ratchet style handle which may be orientated in the most convenient direction. The brake is engaged by rotating the handle clockwise, and disengaged counterclockwise. It is used in the Microbe as well as the Wheel Block (BGS008).



Magnetic Wheel

BTS031

The Magnetic Wheel is used in the Microbe as well as the Wheel Block BGS008. In both applications, two Magnetic Wheels may be installed to effectively double the attraction force.



Microbe Nose

BTS032

The Microbe Nose replaces the Rotix Nose. It provides additional clearance for operating in a longitudinal direction. It includes one removable knob.



Microbe Swivel Nose

BTS034

The Microbe Swivel nose allows probe holders to pivot to accommodate different diameter piping and vessels.



Low Profile Nose

BTS035

The Low Profile nose allows probe holders to be placed beside a Microbe or Rotix body while maintaining a low profile.



Manual Chain Scanner



Rotix

The Rotix is a manual encoded chain scanner to be used on piping or tubing for circumferential scanning. Use the Rotix sizing chart to determine the number of long links and short links to suit your pipe diameter range.

Includes:

- | | |
|----------|------------|
| ■ CES002 | Short Link |
| 1 CES003 | Catch link |
| 1 CES004 | Rotix Cart |
| 1 CES005 | Buckle |
| ■ CES009 | Long link |

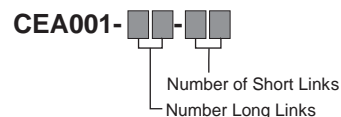

Rotix Case

CEA002

A heavy duty polypropylene protective case, complete with custom milled high density foam inserts and pullout.

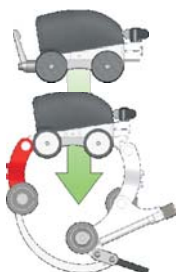

Microbe to Rotix Conversion Kit

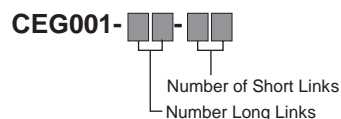

This conversion kit includes all components required to convert a Microbe to a Rotix.

Kit includes:

- | | |
|-------------|----------------------|
| ■ CES002 | Short Link |
| 1 CES003 | Catch link |
| 1 CES005 | Buckle |
| ■ CES009 | Long link |
| 1 CES011 | Rotix nose |
| 4 CES012 | Rotix wheel |
| 1 CES013 | Rotix tail |
| 1 MD050-010 | Screw for Rotix nose |



Short Link

CES002

A minimum of two short links are required for infinite adjustability of the Rotix scanner. Also, short links are required for pipe diameters less than 24.5cm (9.6i). See Rotix sizing chart.



Catch Link

CES003

The Catch link is used in conjunction with the Buckle to clamp the Rotix to the pipe. It is colored to distinguish it from the short links.



Rotix Cart

CES004

The Rotix cart comes complete with the integrated encoder base, removable handle, Rotix nose, Rotix tail, four urethane wheels and one removable knob.



Buckle

CES005

The Buckle features a quick release over-center mechanism which provides an easy method of clamping the Rotix on the pipe. It also provides fine adjustment of the chain tension.



Long Link

CES009

Long links are for use on pipes with outer diameters greater than 24.5cm (9.6i). The length of one long link is roughly equivalent to the length of three short links. See Rotix sizing chart.



Rotix Nose

CES011

The Rotix Nose provides a connection point on the front of the cart for the chain and a slide bar. It includes one removable knob.



Rotix Wheel

CES012

All wheels are coated with urethane to reduce the effects of foreign debris obstructing the rolling of the scanner.



Rotix Tail

CES013

The Rotix tail provides a connection point on the rear of the cart for the chain. Note: the Rotix tail and Microbe brake cannot be used simultaneously.



Short Link with Dovetail

CES024

These links are similar to standard links but include a dovetail for mounting extra hardware.



Divisible Conduit Mounting Bracket

CES025

Divisible Conduit is available to bundle extra cables. The Mounting block allows the conduit to be mounted to any feature with a dovetail such as a link or frame bar.



Low Profile Nose

BTS035

The Low Profile nose allows probe holders to be placed beside a Microbe or Rotix body while maintaining a low profile.



Modular Manual Scanning System



Cross Block

BGS001

The Cross Block is used to connect two components together with one oriented perpendicular to the other.



Connector Block

BGS003

The Connector Block is used to connect two components in-line with each other.



Pivot Block

BGS004

The Pivot Block is used to connect two components together and provide one lockable degree of freedom between the components.



Wheel Block

BGS008

Three of the sides of the Wheel Block feature dovetail grooves so that it may be attached to other components. A Brake (BTS018) may be installed in the fourth side to lock the wheel. The wheel block includes a magnetic wheel (BTS031) fastened to the axle.



Stick

BGS016-

The Stick is a basic building component with dovetail grooves on all six sides. Various lengths are available to provide versatility.



Bar Length (cm)
6
8
10
12
14
16
18
20



Swivel

BGS017

The Swivel connects two components together at right angles and provides one degree of freedom.



Encoded Wheel Block

BGS019-A30

The Encoded Wheel Block contains an optical encoder to provide position location during scanning. It may be plugged into any standard Jireh umbilical. Patch cables are available to input the encoder signal into most major instruments.



Frame Side Member

BGS021

The Frame Side Members, when fastened together with the included colored nut, form the structural sides of the Stix frame. The mating faces lock together to provide adjustment of the frame arc. The Frame Side Members also provide mounting points for the Wheel Blocks and Slide Bars (BG0038-XX)



Frame End

BGS022

The Frame End provides a mounting point for the final Slide Bar (BG0038-XX) in the Stix frame.



Stix Frame

The STIX Frame is used to create a framework to hold probe holders for scanning on ferrous surfaces. * The number of Slide Bars is usually one more than the number of Frame Side Member pairs. If Y-axis is required reduce the number of Slide Bars by the number of Y-axis required.

Included Components:

(4)BGS008, BGS021, (2)BGS022, (1)BGS024, BG0038-XX

BGS023-2-3-20 (shown)

See BGS032 Sizing Information on page ?

BGS023-

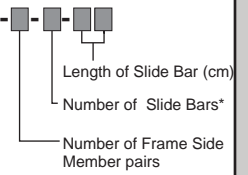

Encoder Arm

BGS025

The Encoder Arm may be mounted on any Slide Bar with its integrated dovetail clamp.



Wheel Block Bracket

BGS029

The wheel block bracket can be used to mount a wheel block (BGS008) to a slide bar.



Spring Loaded Encoder

BGS030-A30

Encoder Assembly may be mounted on any Slide Bar with its integrated dovetail clamp. It includes a non-magnetic wheel which remains in contact with the inspected surface by means of a torsion spring. It may be plugged into any standard Jireh umbilical. Patch cables are available to input the encoder signal into most major instruments.



Double Wheel Block Bracket

BGS048

The Double Wheel Block Bracket is used to mount 2 Wheel Blocks (BGS008) to a Slide Bar.



Slide/Frame Bar

BG0038-

The Slide Bars complete the structure of the Stix frame by joining the two sides formed by the Frame Side Members. They provide dovetail grooves into which the Probe Holders, Stix Encoder, Umbilicals, or other accessories may be attached.

Slide Bar Length (cm)	
20	40
25	45
30	55
35	

BGS032 Sizing Information

The Stix frame is constructed by joining pairs of Frame Side Members with cross members, or Slide Bars. The number of Frame Side Member pairs, which depends on the number of probes you wish to hold, may be determined with the following chart:

Part Number	Typical Number of Probes*	Minimum Pipe Diameter cm (in)	Max. Pipe Dia. for good Tracking, cm (in)
BGS023-2-x-xx	4	7.6 (3.0)	91.4 (36.0)
BGS023-3-x-xx	6	7.6 (3.0)	190.5 (75.0)
BGS023-4-x-xx	8	14.0 (5.5)	289.6 (114.0)
BGS023-5-x-xx	10	20.3 (8.0)	388.6 (153.0)
BGS023-6-x-xx	12	26.3 (10.5)	487.7 (192.0)

*based on one pair of probes per Slide Bar with one Slide bar left empty for umbilical(s) mounting. For Slide Bar lengths less than 30cm, 2 probes may not fit. Also, it is possible to fit more than two probes side-by-side on the longer Slide bars

The length of the Slide Bars may be determined as follows: First, calculate the maximum required distance 'D' (see figure below) from the following: $D = A + (2 \times B)$ where A is the maximum distance required between probe faces and B depends on your wedge;

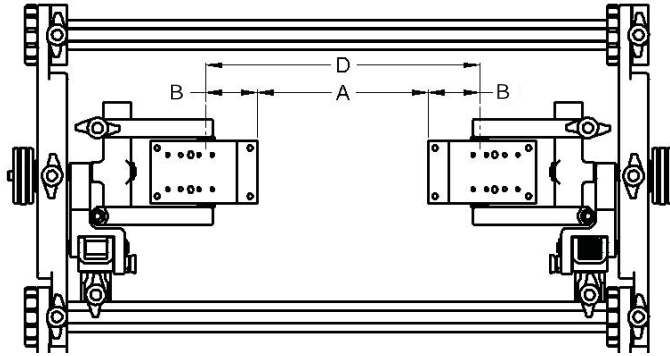

Second, use the chart below to find the P/N of the frame which has a maximum distance D greater than or equal to the D value calculated above. Ensure you are in the correct column for your probe holder size.

Part Number	Maximum Distance D, cm (in)		
	Small Probe Holder	Large Probe Holder, Std Arm	Large Probe Holder, Ext. Arm
BGS023-x-x-15			
BGS023-x-x-20	2.6 (1.03)		
BGS023-x-x-25	7.6 (3.00)	2.6 (1.03)	
BGS023-x-x-30	12.6 (4.97)	7.6 (3.00)	4.5 (1.78)
BGS023-x-x-35	17.6 (6.94)	12.6 (4.97)	9.5 (3.74)
BGS023-x-x-40	22.6 (6.94)	17.6 (6.94)	14.5 (5.71)
BGS023-x-x-45	27.6 (8.90)	22.6 (6.94)	19.5 (7.68)
BGS023-x-x-50	32.6 (12.84)	27.6 (8.90)	24.5 (9.65)



Magnetic Remote Transport Vehicle

CRAWLER

Use the part numbering system below to designate the crawler



AAA003-

- A - No Attachments
- BCMAPRB - Camera & Probe Lift Actuator
- BCMAPG - Camera (see options) & expanability for future Probe Lift
- CPR - Probe Lift Actuator (see options)
- CPG - Expanability for future Probe Lift
- E - Rear wheel Encoder (see options)
- N - No Encoder on rear wheel

Encoder

An optional encoder is available to provide positional feedback. Custom encoder input cable are available for all major instrument manufacturers.

E

Probe Lift Actuator

A small, lightweight linear actuator is available to lift a probe or inspection device from the driving surface. The actuator has 1" of vertical travel and is controlled with the handheld control unit.

PR

- F - 3/8" Dia Probe Clamp
- G - 3/4" Dia Probe Clamp
- H - 0.8" Dia Probe Clamp

Video Camera System

A video camera can be mounted on the Tripod for visual inspection or as a driving aid. All cameras are watertight. Mounting hardware is provided to mount the camera to the Tripod body. The video feed is sent down the standard umbilical; no extra cabling is required.

CMA

SYSTEM COMPONENTS (Required)



Controller

AAS021

Hand held controller used to remotely drive the Tri-pod via the control cable. It consists of 2 joystick controls, 2 selection buttons and a LCD screen housed in a rugged plastic enclosure.



Power Supply

AAS064

85 - 264VAC 45 - 65 Hz 1 phase power supply.



Control Cable

AAS055-

The control cable is used to connect the controller to the main umbilical. Standard cables are available in 6,9,15 and 30m lengths. (Contact Jireh for custom cable lengths)

Cable Length (m)	
06	15
12	30



Umbilical

AAS037- A-

Rugged polyurethane umbilical. Includes 4 RG-174/U coaxial conductors and a Polyurethane water line.

Cable Length (m)	
23	38
30	46



Flux Breaker Mat

AAS061

The flux breaker mat is used to mount and remove the Tri-pod from

SYSTEM ACCESSORIES (Optional)



TriPod Case

AAS059

A rugged water tight case with custom foam interior.



Case for P/S & Control

AAS060

A rugged water tight case with custom foam interior.

Water System

CMA001- 

The Tripod is available with a 60psi positive displacement pump, 1 liter accumulator tank, and valving mounted in a rugged plastic case. This pump system plugs directly into the breakout bell of the Tripod

A - Large Case - Pump and umbilical storage

B - Small Case - Pump

BILLY GOAT

Automated Pipeline Girth Weld Scanner



Billy Goat (carriage only, no motor)

The Billy Goat is a drive platform to be used with pipe weld bands ranging from 80mm to 140mm wide. Quick change idler drive wheel cartridges allow for easy field maintenance with minimal downtime.

See Billy Goat Ordering Information for further details

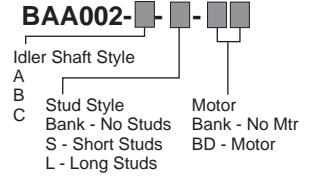

Billy Goat Motor Driver/Controller

BAA004

The Motor Controller is used to drive the Billy Goat. Some key features are; auto mode, jog mode, 4 configurable setups, selectable units and a diagnostic mode.



Billy Goat Remote Pendant

BAA005

The Remote Pendant is used to remotely operate the Billy Goat by either connecting it to the motor controller or to the end of the umbilical cable.



Billy Goat Pendant Controller Cable

BAA007- 

The Controller Cable is used to connect the Pendant to the Motor Controller.

Cable Length (m)
006m
015m



Billy Goat Motor to Controller Cable

BAA008- 

The Motor Cable is used to connect the Billy Goat Motor to the controller.

Cable Length (m)
0.6m
1.5m



Billy Goat Power Supply

BAA011

Power supply 400W 24VDC 16.7A output. 80-270VAC input.



Billy Goat Umbilical Cable

BAA012- 

The Billy Goat Umbilical provides power and signal to the motor and motor controller and also used to give an encoder output signal for the position location of the scanner.

Cable Length(m)
005 015
010 025
020



Pendant to Umbilical Cable

BAA013- 

This cable allows the operator to connect the Pendant to the end of the Umbilical for remote operation.

Cable Length(m)
005
010



Billy Goat Water Manifold Kit

BAG001

This water manifold kit mounts to the standard Billy Goat allowing distribution of coupling fluid and or mounting of the GE[®] Weldstar[®]* inspection system

*Both "GE" and "Weldstar" are registered trademarks of the General Electric Company



Billy Goat Spare Fasteners Kit

BAG002

Common fasteners and hardware replacement kit for the Billy Goat Carraige.



Billy Goat Probe Holder Frame

The Probe Holder Frame is used to mount probe holders, an encoder and extra accesories to the Billy Goat carraige.

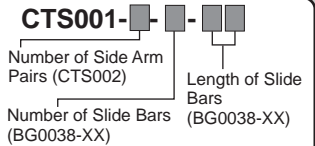

Billy Goat Frame Side Arm

CTS002

The Frame Side Members are used to create a frame to hold probe holders and accessories. When fastened together they are adjustable to compensate for different size piping.



Billy Goat Frame Arm End

CTS003

The Frame End provides a mounting point for the final Slide Bar in the Stix frame.



Spring Loaded Encoder

BGS030-B60

Encoder Assembly may be mounted on any Slide Bar with its integrated dovetail clamp. It includes a non-magnetic wheel which remains in contact with the inspected surface by means of a torsion spring. It is designed to be plugged directly in the Billy Goat Motor Controller. Patch cables are available to make a connection between the Encoder output on Billy Goat Umbilical and most instrumentation



Billy Goat Idler Shaft Cartridge - A

BAS002

Replacable Idler Shaft Cartridge Assembly, See ordering information for idler shaft details.



Billy Goat Idler Shaft Cartridge - B

BAS016

Replacable Idler Shaft Cartridge Assembly, See ordering information for idler shaft details.



Billy Goat Idler Shaft Cartridge - C

BAS019

Replacable Idler Shaft Cartridge Assembly, See ordering information for idler shaft details.



Billy Goat Idler Shaft Cartridge - D

BAS023

Replacable Idler Shaft Cartridge Assembly, See ordering information for idler shaft details.

BAA002 Ordering Information

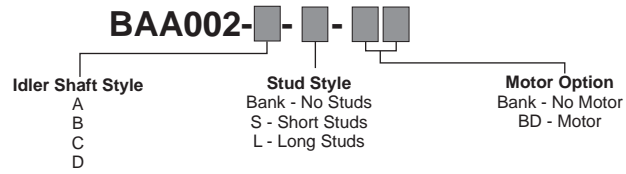

Idler Shaft A

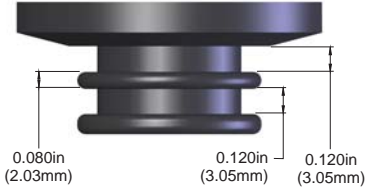

Idler Shaft B

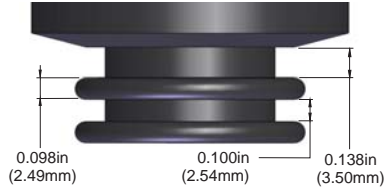

Idler Shaft C

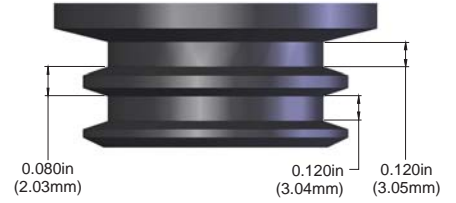

Idler Shaft D

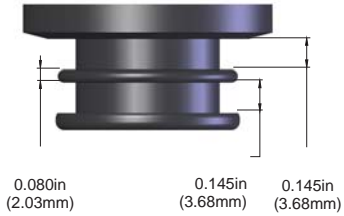

Billy Goat Stud Options

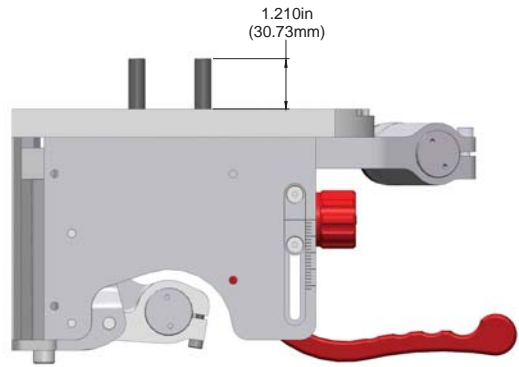
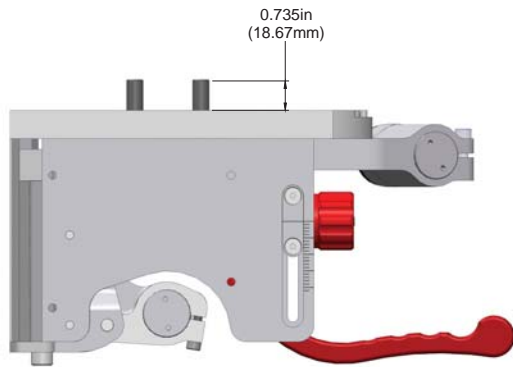

Y Axis Adjustment



CJA001-45-E Shown

Y-Axis

Included Components:

- 1 CJS001
- 2 CJS008
- 1 BG0038-XX
- 1 CJ0022
- 1 CJS005

Slide Bar Length	Slide Configuration
20	Single Slide
25	Single Slide
30	Dual Slide
35	Dual Slide
40	Dual Slide
45	Dual Slide
50	Dual Slide
55	Dual Slide

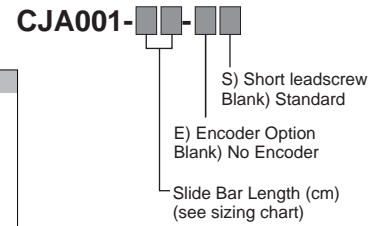

Main Knob

CJS001

The bracket of the Main Knob assembly attaches into the Slide Bar dovetail groove and houses the bearings for the knob. The knob is clamped onto the lead screw so that the knob and the lead screw rotate as one. The Main Knob assembly may be positioned on the Slide Bar wherever it is most convenient.



Slide

CJS008

A Probe Holder may be attached to each Slide with the incorporated dovetail grooves. The small knob allows independent translation of each slide along the Slide Bar. To do so, the lock knob must be loosened first.



Slide Bar

BG0038-

The Slide Bar is a component borrowed from the Stix scanner (see Stix section). Different lengths of Slide Bars are available. The length of the Slide Bar makes up a portion of the part number of a Y-Axis assembly. See sizing information for details

Slide Bar Length (cm)	
20	40
25	45
30	50
35	55



Lead Screw

CJ0022-

The Lead Screw is rotated manually by turning the Main Knob. It provides the lateral force on the Slides to induce motion. It is made of durable stainless steel.

Lead Screw Length (cm)	
13	33
18	38
20	43
23	48
28	



Encoded Lead Screw

CJS009-

The Encoded Lead Screw is a lead screw with one end machined to engage with and drive the Encoder.

Encoded Lead Screw Length (cm)	
16	33
18	38
21	43
23	48
28	



Encoder

CJS005-A30

The Encoder attaches to the Slide Bar and engages with the Encoded Lead Screw to provide positional feedback on lateral position of the probe(s). It may be plugged into any standard Jireh umbilical that contains a 6-pin auxiliary input output is RS422 compatible line driver, 271counts/inch (quadrature decode), power requirements are 4.5-5.5VDC 25ma.

Universal Components and Accessories



Cross Block

BGS001

The Cross Block is used to connect two components together with one oriented perpendicular to the other.



Connector Block

BGS003

The Connector Block is used to connect two components together in-line with each other.



Pivot Block

BGS004

The Pivot Block is used to connect two components together and provide one lockable degree of freedom between the components.



Wheel Block

BGS008

Three of the sides of the Wheel Block feature dovetail grooves so that it may be attached to other components. A Brake (BTS018) may be installed in the fourth side to lock the wheel. One (1) BTS031 Magnetic Wheel is included.



Double Wheel Block Bracket

BGS048

The Double Wheel Block Bracket is used to mount 2 Wheel Blocks (BGS008) to a Slide Bar.



Stick

BGS016-

The Stick is a basic building component with dovetail grooves on all six sides. Various lengths are available to provide versatility.

Bar Length (cm)	
6	14
8	16
10	18
12	20



Swivel

BGS017

The Swivel connects two components together at right angles and provides one degree of freedom as shown.



Stabilizer Arm with Rotating Joint

CMS006

The Stabilizer Arm with Rotating Joint may be used like the Fixed Stabilizer Arm, but also provides an attachment point for a Stix Frame Side Member (BGS021 see Stix section). A Wheel Block (BGS008) may then be attached to the Stix Frame Side Member to increase tracking of a Microbe scanner on larger pipes.



Handle

CMS004

The Handle may be attached into any dovetail groove.



Removable Knob, M4

PHS021

The Removable Knob provides a tool less method for tightening and loosening most M4 socket head cap screws. It is removable to improve flexibility.



Removable Knob

BTS017

The Removable Knob, which is included by default with most scanning systems, provides a tool less method for tightening and loosening most dovetail connections. It is removable to improve flexibility.



Brake

BTS018

The Brake features a ratchet style handle which may be orientated in the most convenient direction. The brake is engaged by rotating the handle clockwise, and disengaged counterclockwise. It is used in the Microbe as well as the Wheel Block (BGS008).



Universal Tool

CMA006

This tool may be used where a Removable Knob is not feasible because of space restraints. The opposite end may be used for most locations where hex socket screws were necessary.



Encoded Wheel Block

BGS009-A30

The Encoded Wheel Block is like the Wheel Block (BGS008), but provides encoder feedback. Output is RS422 compatible line driver, 271counts/inch (quadrature decode), power requirements are 4.5-5.5VDC 25ma. One (1) BTS031 Magnetic Wheel is included.



Magnetic Wheel

BTS031

The Magnetic Wheel is used in the Microbe as well as the Wheel Block BGS008. In both applications, two Magnetic Wheels may be installed to effectively double the attraction force.

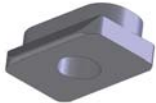

Dovetail Nut

BT0014

The dovetail nut is used in many components to connect with dovetail grooves on other components.



Long Wheel Block Bracket

BGS045

The long wheel block bracket can be used to mount a wheel block (BGS008) to a frame member or slide bar. Vertical offset is 0.75"



Short Wheel Block Bracket

BGS029

The short wheel block bracket can be used to mount a wheel block (BGS008) to a frame member or slide bar. Vertical offset is 0.5"



Offset Block

PHS020

The offset block can be used to mount a probe holder when greater offset is needed between frame member or slide bar and scanning surface. Vertical offset is 0.31". Horizontal offset is 0.9"



Stix Wrench

BG0041

The Stix Wrench is used for loosening and tightening the colored nut on Frame Side Members (BGS021) and Frame Ends (BGS022)



Irrigation Manifold

CMG002- 

The irrigation manifold can be configured for different sizes of inlet and outlet tubing. It has a maximum of 6 outlets and comes with 4 plugs to block unused ports. 4m of outlet tubing is also supplied.

Outlet tube O.D.
1/16", 3/32", 1/8", 3/16"
Inlet tube O.D., 1/8", 4mm,
6mm, 1/4", 8mm, 3/8", 10mm



Cable Clamp

CMA007

The Cable Clamp is used to hold an encoder cable to any scanning system. It also acts as a strain relief.



Divisible Conduit Mounting Bracket

CES025

The Divisible Conduit Mounting Bracket is available to bundle extra cables Using PMA-Flex. The bracket allows the conduit to be mounted to any feature with a dovetail such as a link or frame bar.



Spring Loaded Encoder

BGS030-A30

Encoder Assembly may be mounted on any Slide Bar with its integrated dovetail clamp. It includes a non-magnetic wheel which remains in contact with the inspected surface by means of a torsion spring. Patch cables are available to input the encoder signal into most major instruments.

Probe Holders



Fixed Joint Probe Holder

The Fixed Joint Probe Holder has a fixed mounting position when mounted to a slide bar. Optional arm and pivot button styles are available (see Arm and Pivot Button style charts)

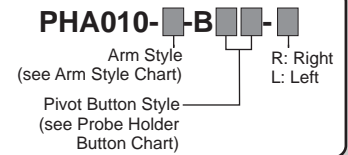

Swing Joint Probe Holder

The Swing Joint Probe Holder has an adjustable position when mounted to a slide bar. Optional arm and pivot button styles are available (see Arm and Pivot Button style charts)

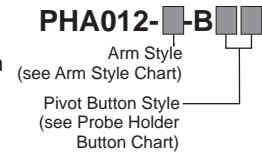

Standard Arm Set, (A)

The Standard Arm Set has an adjustable pivot length range of 1.56in (39.6mm) - 1.90in (48.3mm). See the Arm Style Chart

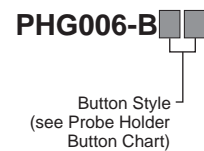

Short Arm Set, (B)

Short Arms have an adjustable pivot length range of 0.76in (19.3mm) - 1.10in (27.9mm). See the Arm Style Chart

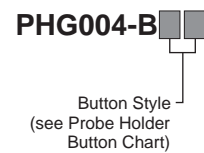

Long Arm Set, (C)

Long Arms have an adjustable pivot length range of 2.16in (54.9mm) - 2.50in (63.5mm). See the Arm Style Chart

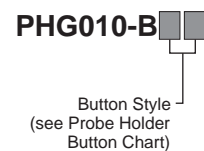

Standard Drop Arm Set, (D)

Standard Drop Arms have an adjustable pivot length range of 1.22in (31.0mm) - 1.90in (48.3mm). The drop arms raise the probe pivot 0.27in (6.8mm). See the Arm Style Chart

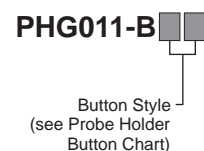

Short Drop Arm Set, (E)

Short Drop Arms have an adjustable pivot length range of 0.76in (19.3mm) - 1.44in (36.6mm). The drop arms raise the probe pivot 0.27in (6.8mm). See the Arm Style Chart

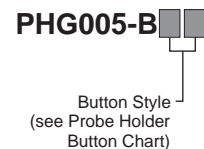

Long Drop Arm Set, (F)

Long Drop Arms have an adjustable pivot length range of 1.82in (46.2mm) - 2.50in (63.5mm). The drop arms raise the probe pivot 0.27in (6.8mm). See the Arm Style Chart

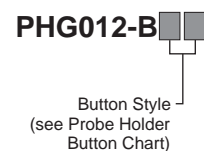

Standard Extra Drop Arm Set, (G)

Standard Extra Drop Arms have a pivot length of 1.90in (48.3mm). The drop arms raise the probe pivot 1.07in (27.8mm). See the Arm Style Chart



Short Extra Drop Arm Set, (H)

Short Extra Drop Arms have a pivot length of 1.1in (28.0mm). The drop arms raise the probe pivot 1.07in (27.8mm). See the Arm Style Chart





Probe Holder Button

Different diameter Probe Pivot Buttons are available to accommodate different wedge styles. Contact Jireh for custom button sizes.

Note: Hex size divided in half should not exceed distance from the center of the hole in the wedge to the bottom of the wedge.

PH0011-

Button Style
(see button size chart)

PHA010 / PHA012 Sizing Information

Use the Probe Holder Arm Style chart below to determine which type of probe holder arms are suitable for your wedge(s)

Arm Style	Arm Type	Pivot Length (L)	Width (W)
A	Standard	39.6 - 48.3mm (1.56 - 1.9")	13 - 45mm (0.51 - 1.77")
B	Short	19.3 - 27.9mm (0.76 - 1.1")	13 - 45mm (0.51 - 1.77")
C	Long	54.9 - 63.5mm (2.16 - 2.5")	13 - 45mm (0.51 - 1.77")
D	Standard, Drop	31.0 - 48.3mm (1.22 - 1.9")	13 - 45mm (0.51 - 1.77")
E	Short, Drop	19.3 - 36.6mm (0.76 - 1.44")	13 - 45mm (0.51 - 1.77")
F	Long, Drop	46.2 - 63.5mm (1.82 - 2.5")	13 - 45mm (0.51 - 1.77")
G	Standard, Extra Drop	48.3mm (1.9")	13 - 45mm (0.51 - 1.77")
H	Short, Extra Drop	27.9mm (1.1")	13 - 45mm (0.51 - 1.77")

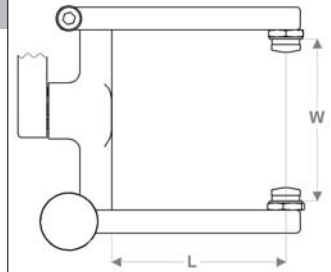

Use the Probe Holder Pivot Button Style chart below to determine which pivot button style is needed

Button Style	Pivot Hole Size	Hex Size
01	8.0mm (0.315")	9.53mm (3/8")
02	5.0mm (0.197")	9.53mm (3/8")
03	2.7mm (0.106")	9.53mm (3/8")
04	9.53mm (0.375")	11.1mm (7/16")
06	3.0mm (0.118")	9.53mm (3/8")
07	2.3mm (0.090")	9.53mm (3/8")
08	Conical Head	9.53mm (3/8")

Umbilicals and Cables



Microbe/Rotix Encoder Breakout Box

UMA003

The Encoder Breakout Box is used to input X and Y encoder feedback into the instrument being used. Contact Jireh for custom patch cords from the breakout box to instrument.



Microbe/Rotix Integrated Umbilical

UMA004-

The Integrated Umbilical is used to input X and Y encoder feedback into the instrument being used. It also includes four coax cables and a coupling fluid tube.

A - Flying Leads
J - Breakout Bell
(see figure 3)

Cable Length (m)
03
05
10
15

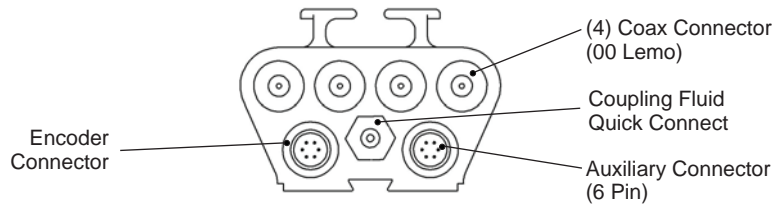

Figure 1



Microbe/Rotix Encoder Cable

UMA005-

The Encoder Cable is used to input X and Y encoder feedback into the instrument being used.

Instrument end termination (see umbilical style chart)

Cable Length (m)
03
05
10
15

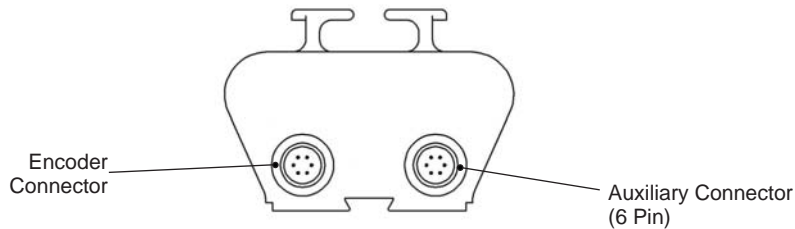

Figure 2



Low Profile Encoder Cable

UMA006-

The Low Profile Encoder Cable is used in low profile applications to input X and Y encoder feedback into the instrument being used.

Instrument end termination (see umbilical style chart)

Cable Length (m)
03
05
10
15



Jireh Bell to Instrument Encoder Cable

UMA007-

This cable is used to provide single axis encoder feedback into the instrument being used.

Instrument end termination (see umbilical style chart)

Cable Length (m)
03
05
10
15



Jireh Encoder to Instrument Encoder Cable

UMA008-

This cable is used to provide single axis encoder feedback from a standard Jireh encoder assembly into the instrument being used.

Instrument end termination (see umbilical style chart)

Cable Length (m)
03
05
10
15

Umbilical Style

Use the Umbilical Style chart below to determine which type of connectors are necessary for your instrumentation.

Umbilical	Company/Instrumentation
A	Flying Leads
B	Olympus OmniScan
C	Olympus Focus LT
E	Olympus Epoch XT
N	Olympus UMB1 Umbilical (single axis encoder output)
B	Harfang X32
F	AGR TD Focus Scan
F	AGR TD Handy Scan
F	AGR TD Scan
F	AGR TD Pocket Scan
G	Sonotron Isonic
J	Jireh Breakout Bell (see Figure 3 below)*
K	AIS NP3 Nanopulser
L	US Ultratek PCIUT3100T
M	Scantech Analyst
P	Sonatest VEO
B	Zetec ZIRCON

* only available with UMA004 Umbilical

Jireh Breakout Bell

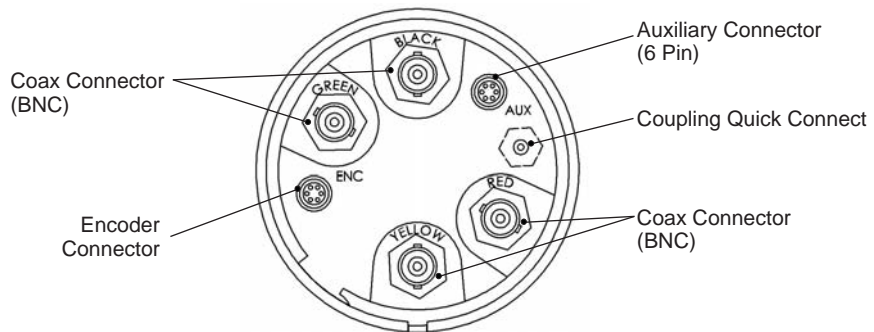

Figure 3